

Ventilation Solutions

IAQ | Canada

50%

of people surveyed were not aware the poor indoor air quality is one of the top 5 most urgent environmental risks to public health.

Filter

80%

of our time is spend indoors.

Ventilate

**7
Years**

Limited warranty on motors

Improving ventilation and airflow is basic to air quality, especially if your home is new or recently remodeled

Indoor Air Quality

Keep your family safe

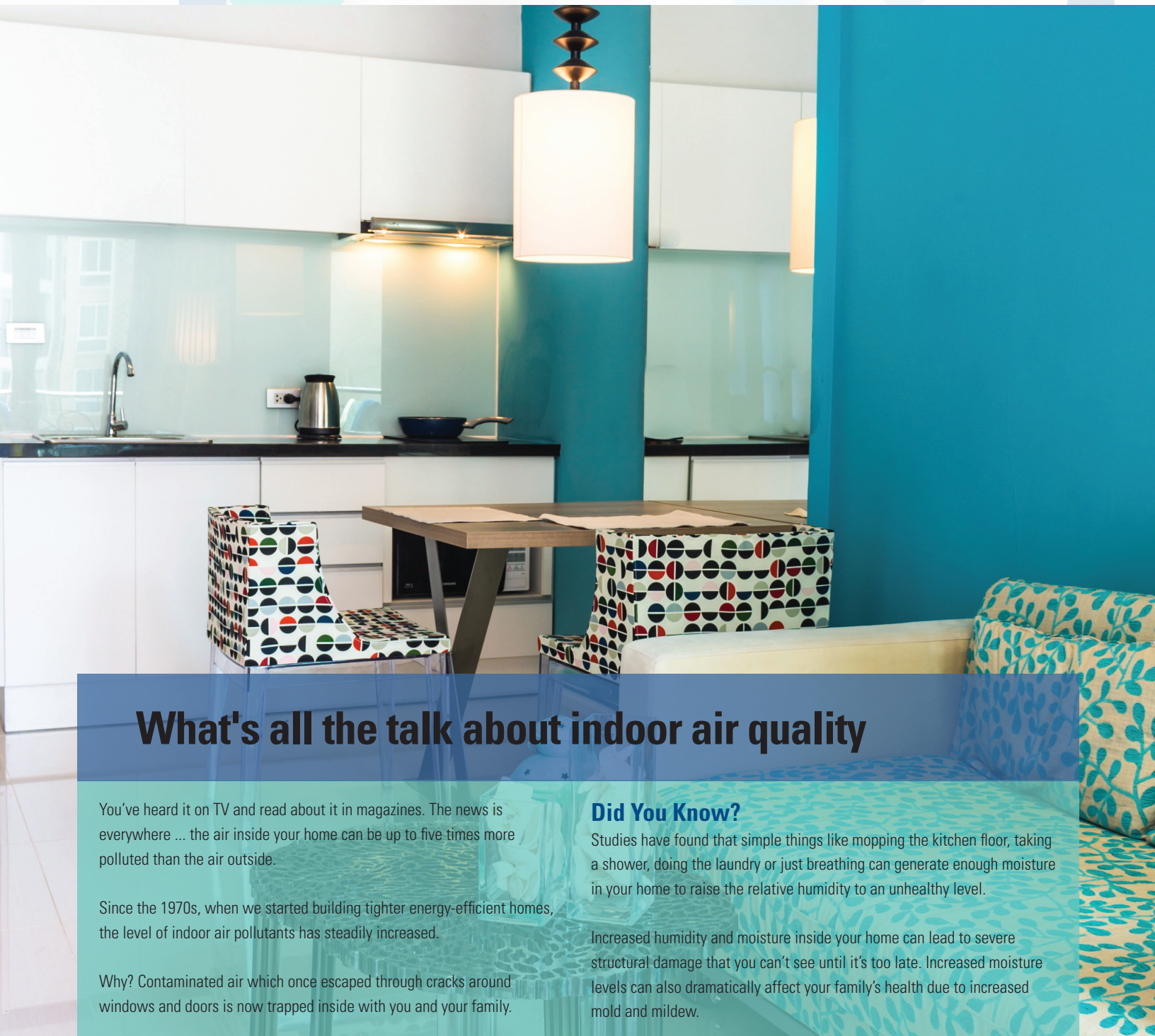

What's all the talk about indoor air quality

You've heard it on TV and read about it in magazines. The news is everywhere ... the air inside your home can be up to five times more polluted than the air outside.

Since the 1970s, when we started building tighter energy-efficient homes, the level of indoor air pollutants has steadily increased.

Why? Contaminated air which once escaped through cracks around windows and doors is now trapped inside with you and your family.

Did You Know?

Studies have found that simple things like mopping the kitchen floor, taking a shower, doing the laundry or just breathing can generate enough moisture in your home to raise the relative humidity to an unhealthy level.

Increased humidity and moisture inside your home can lead to severe structural damage that you can't see until it's too late. Increased moisture levels can also dramatically affect your family's health due to increased mold and mildew.

Safeguard Your Home

Three easy steps



Heat Recovery Ventilators

The basic

What are HRVs

To better understand these products and their function, here are a few things to remember.

Heat Recovery Ventilators are recommended for colder areas of the country that have longer heating seasons.

Heat Recovery Ventilators are complete whole house ventilation systems that incorporate a supply motor and an exhaust motor in one unit. The supply motor draws fresh air in from the outside and the exhaust motor pushes stale contaminated air out. The two air streams are separated by a heat recovery core which tempers the air making it the most comfortable solution for a healthy indoor environment.

For information on how these units can help you save energy and lower heating or cooling costs, read “How Do They Work?”.

Benefits of a Heat Recovery Ventilator

- Brings a continuous supply of fresh, filtered outside air into the home
- Exhausts environmental contaminants for improved indoor air quality
- Saves energy by recovering heat from exhaust air in the winter
- Cools incoming air in the summer when the house air is cooler than the outdoor air
- Controls excess humidity in cooler seasons by introducing outdoor air into the house



Heat Recovery Ventilators Features

Electrostatic Filters

The filters are washable electrostatic type filters that won't need to be replaced.

Fully Insulated Cabinet

Core

The high quality cores offer efficient heat and/or energy transfer, improved defrost characteristics and ease of maintenance.

Motors

Maintenance free operations with an internal thermal overload protection built-in.

Electronic Control Board

Easy to connect to existing HVAC equipment and convenient wall controls.

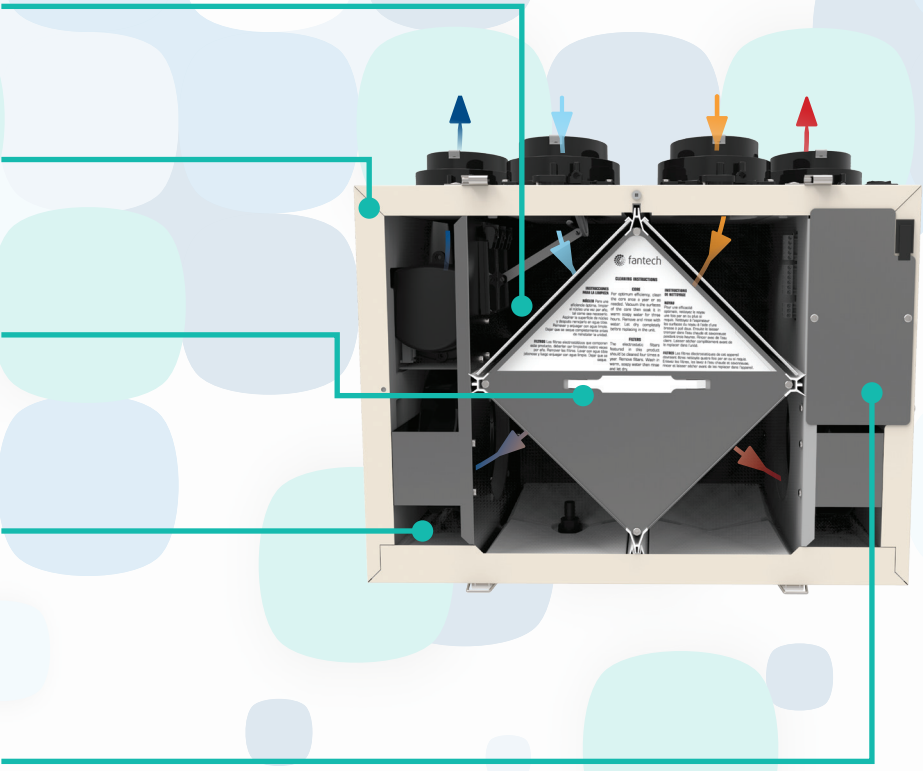

- Stale air to outside
- Fresh air from outside
- Stale air from inside
- Fresh air to inside

How Do They Work?

Heat Recovery Ventilator (HRV)

An HRV is designed to bring a continuous supply of fresh air into a home while exhausting an equal amount of contaminated air. HRVs use what is called a heat recovery core. This special aluminum core transfers heat from the exhaust air stream to the incoming air stream. Fresh incoming air is tempered by the heat that is transferred from the outgoing air so you save on energy costs. Fantech's HRVs are equipped with automatic defrost mechanisms so even if you live in the cold climates you can use your HRV all year long

Energy Recovery Ventilator (ERV)

Fantech's ERV works much like the HRV but it is equipped with a different type core. The energy recovery core at the center of the unit transfers heat and moisture from the incoming air to the outgoing air that was cooled and dried by the building's air conditioner. The air brought into the living area is cooled and the humidity is reduced for maximum comfort. The load on your air conditioner is reduced saving on cooling costs.

The Right Unit:

How many room does your home have?

Use the table below to determine your minimum ventilation needs.

If you choose to use the HRV to provide the required supplemental exhaust for bathrooms or the kitchen, refer to the building code to determine the additional ventilation capacity required.

Number of bedrooms in dwelling unit	Continuous ventilation capacity			
	Minimum		Maximum	
	L/s	cfm	L/s	cfm
1	16	34	24	51
2	18	38	28	59
3	22	47	32	68
4	26	55	38	81
5	30	64	45	95
More than 5	System must comply with Clause 9.32.1.3.1(1)(a)			

* Table 9.32.3.3.A., National Building Code of Canada.

Installation Options

HRVs can be installed as stand-alone systems that use independent ductwork or they can be connected to the existing duct of your forced air heating or cooling system.

Fully dedicated system

Provides the best fresh air distribution in the house; lowest operation cost since the furnace/air handler is not needed.

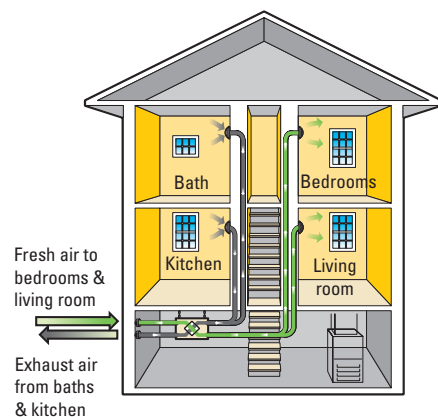

Partially dedicated system

Conditions the fresh air from the furnace then distributes it throughout the house.

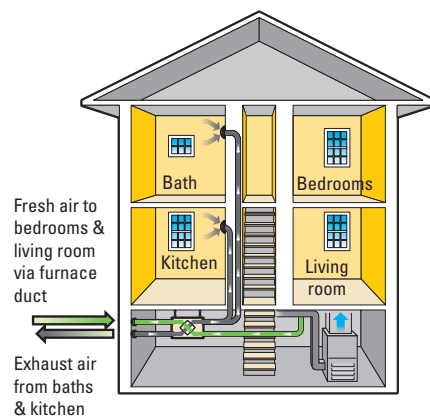

Simplified installation

Least expensive installation type.

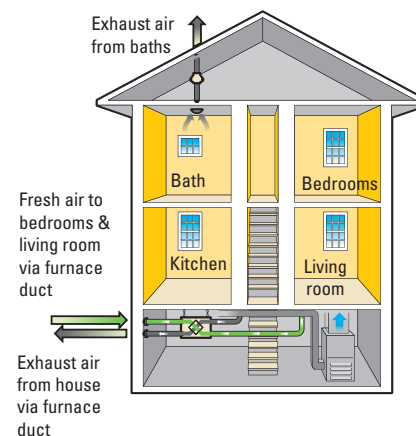

Filtration Whole house HEPA

Fantech provides an added solution for better indoor air quality with the Whole House HEPA filtration unit. This small, compact unit installs on the existing ductwork of your furnace/air handler or can be used as an independent system mounted in the attic, crawl space or closet.

It is designed to clean and filter the total volume of air in an average 1800 sq. ft. (167 m²) house once an hour. Larger homes will take slightly longer for complete air change. Mold spores, pet dander, cooking odors, dusts, dust mites and their by-products are all captured in a series of three filters. The prefilter collects the largest particles while the carbon filter absorbs odors. The third filter is a true, certified HEPA filter which collects particles down to 0.3 microns.



Three models to choose from

CM3000

Collar mount model comes with for collars, two pieces of UL Listed 8" flex duct and hanging chains.

CM3000I

Insulated unit is used in unconditioned spaces such as attics and garages. Insulated outer shell prevents condensation problems. Kit includes hanging chains.

DM3000P

Duct mount model features integrated airflow sensor switch which energizes the unit any time furnace/air handler operates. Designed with a backplate that allows direct connection of the unit to air handler or furnace.

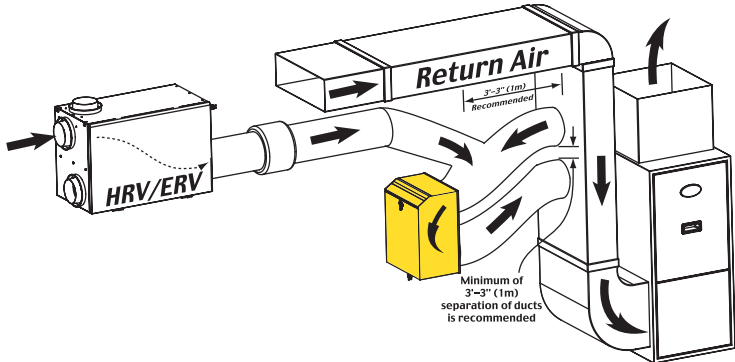
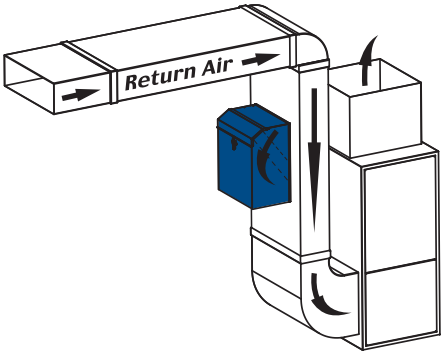
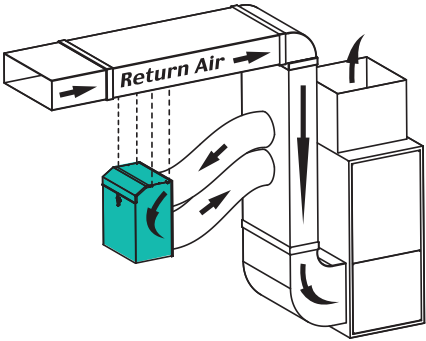

Canada - Bouctouche, NB



Distributed Locally by:



Customer Support:

Canada

800.565.3548

CANADAsupport@fantech.net



Send Orders:

Canada

877.747.8116

CANADAorders@fantech.net



fantech[®]
a systemair company

Fantech reserves the right to modify, at any time and without notice, any or all of its products' features, designs, components and specifications to maintain their technological leadership position. The application rendering presented in this brochure is for visual presentation purposes only. Please, contact a building professional for technical guidance.